

Front View

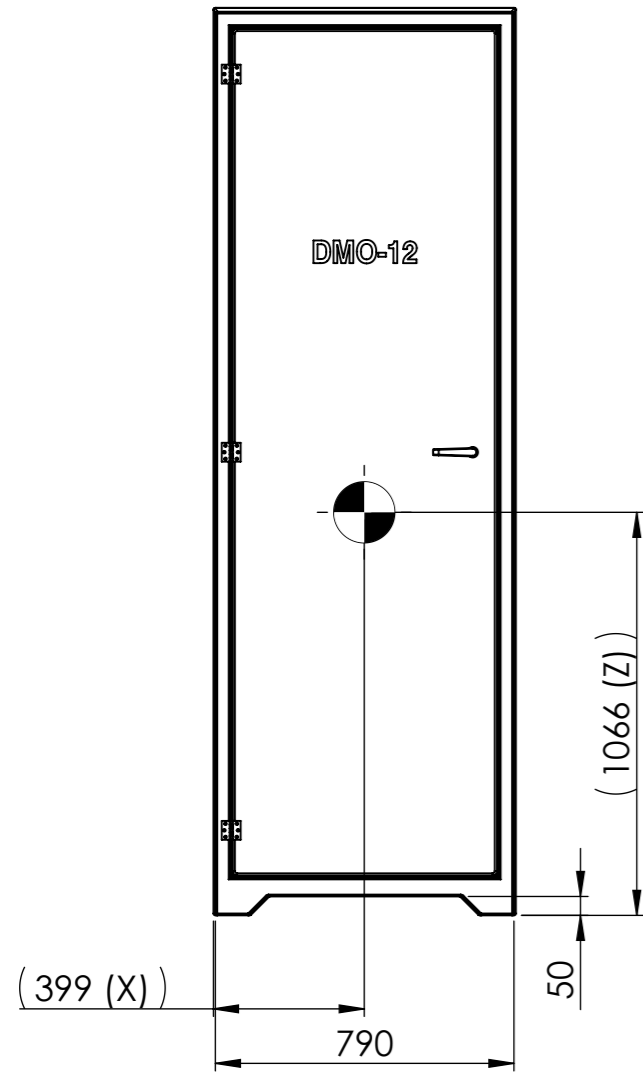

Side View

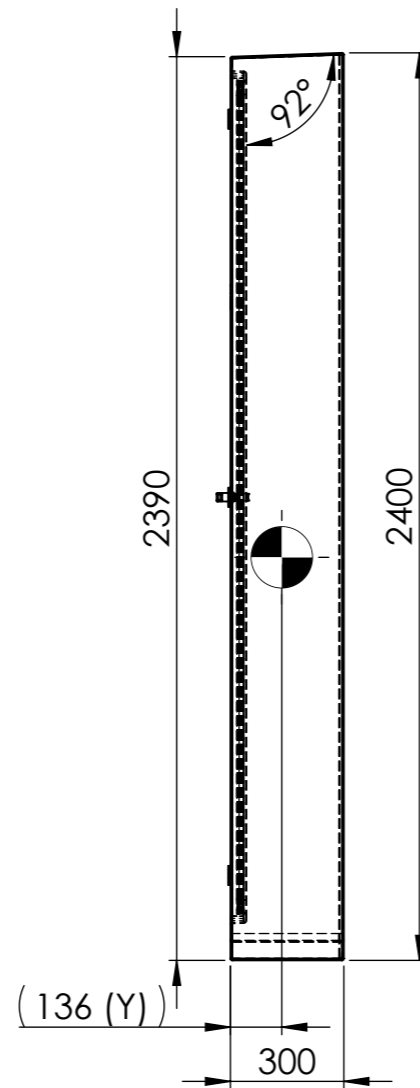

ISO View

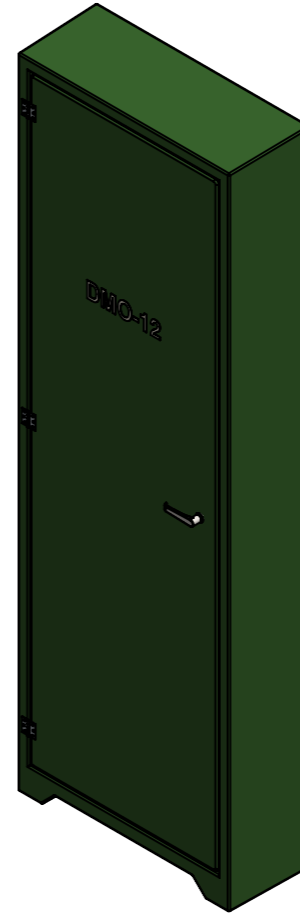

Rear View

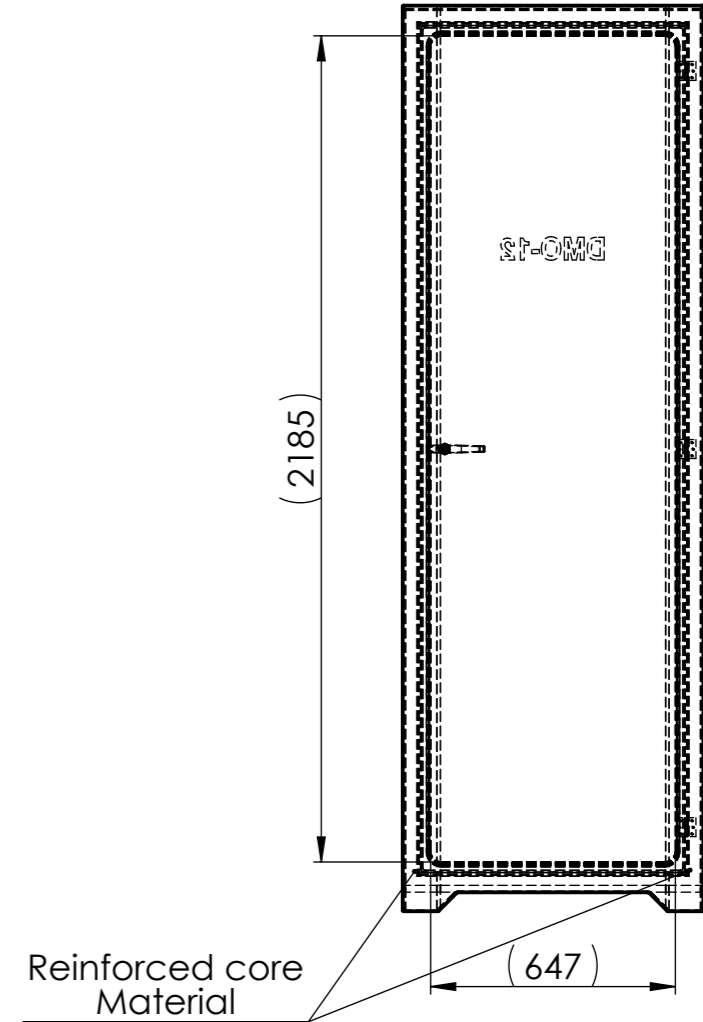

Top View

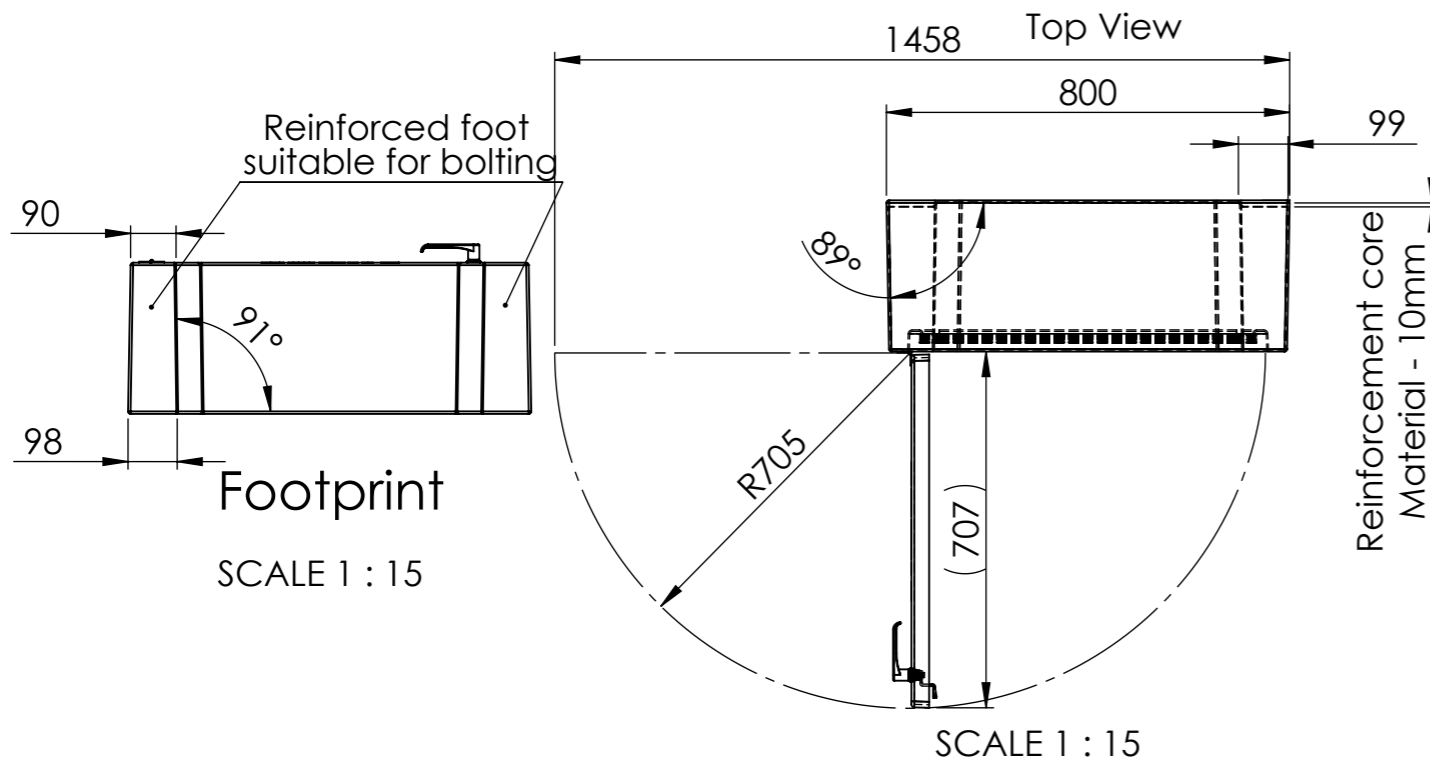

Colour	RALxxxx
Material	3-4mm GRP
Lock and hinges	Stainless steel
Weight cabinet	xxKg
Weight cabinet incl. content	Invulbaar
C.O.G.	X 399 / Y 136 / Z 1066 from datum
Text on cabinet	Invulbaar
Tag on cabinet	Invulbaar
Mounting instructions	Invulbaar
Storage for	

	Date	Name	SW Filename
	13-2-2023	B.S.	DMO_12_00
Dräger Nederland B.V. Marine & Offshore Beurtschipperstraat 1 3194 DK, Hoogvliet-RT the Netherlands		Comments: +31 10 2952772	
Scale: 1:20	Projection	Description:	Art.Nr:
Units: mm		DMO Cabinet 12	DMO_12
			Sheet
			1 of 4
			Format:
			A3